



# GEOsniff® AUTO BYPASS (patent pending)

Automatic insertion and removal of a GEOsniff®<sup>TP</sup> MEASUREMENT PIG for reliable continuous operation of an geothermal probe as well as a long-term monitoring of the temperature-depth profiles in small and large geothermal plants and for usage as groundwater measuring point.

Field of application	Automated, continuous measuring/monitoring of the depth-temperature profile of a geothermal probe as well as using it as a temperature-depth measuring site and the operational monitoring of a geothermal plant
Design	Robust housing made of POM
Measuring principle	GEOsniff® <sup>TP</sup> MEASUREMENT PIG is automatically inserted and removed, get charged and read out wirelessly
Measuring cycle	Individually configurable, depending on the length of the geothermal probe
Integrated measuring sensors, interfaces	Temperature sensor for calibration check, conductivity for brine (optional), interface to the heating pump and further digitals I/O's, external sensor interfaces (optional)
Geothermal probe connection properties	Threaded connection G1 1/4" for steel sleeve clamp or welding sleeve for 32 mm or 40 mm probe tube, mounted directly via the geothermal probe in a mounting bay
Online connection and interfaces	Prepared for online connection with YouFootprint® for visualization of measuring data via smartphone app (Android and iOS) and push notification for alarm messages, remote maintenance via GSM/UMTS/LTE, connection to building management system via BACnet IP, KNX IP, XML etc. Further protocols/data formats optional
Maintenance	Maintenance-free operation, allows remote monitoring of the operating condition and remote maintenance of the system
Power supply	24 VDC, supply via external 230 VAC power supply
Power consumption	2 W standby, 15 W measurement operation, automatic temperature-depth measuring point depending on pump power consumption, with 100 m probe, 100 W in pumping operation f.e.
Installation requirements	Mounting bay with diameter at least $\varnothing = 800$ mm
Dimensions / weight	360 x 120 x 112 mm / approximately 5 kg
Protection type	IP65



1 Leading

2 Return

3 24 VDC and ethernet socket, IP65, optional connection for heating pump, digital I/O 's

4 Dummy plug for removing the GEOsniff® TP MEASUREMENT PIG in attached geothermal probes

5 GEOsniff® APP for control, data analysis and visualization with test reports



Required installation space on the example for use as a self-sufficient depth-temperature measuring site

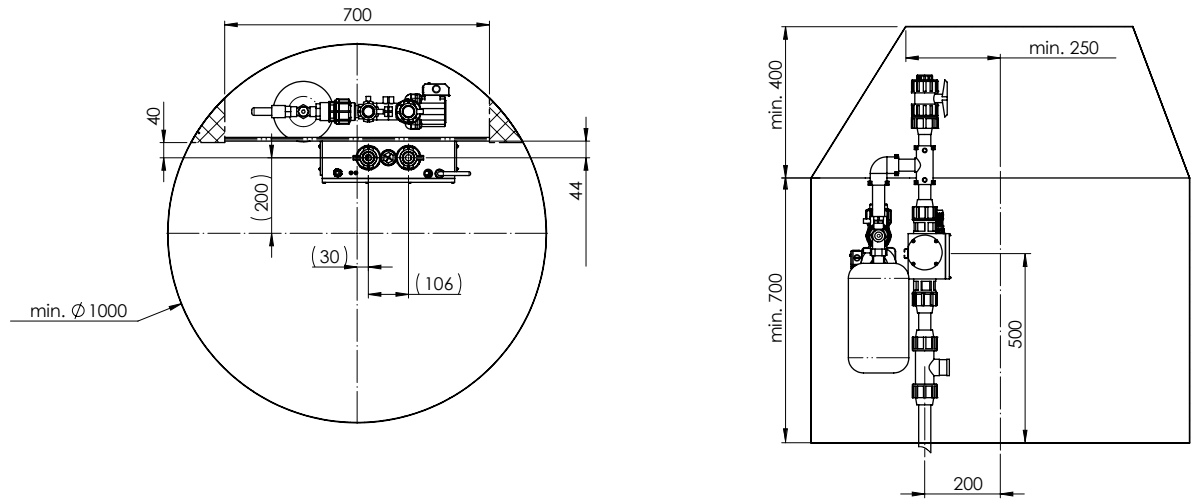

Dimensions of GEOsniff® AUTO BYPASS

